

Installation Note

Source Attenuators and Bias Tees Upgrade Kit

For PNA Series Microwave Network Analyzers (E8362A)

Network Analyzer Model Number	Upgrade Kit Part Number
E8362A	E8362-60103



Agilent Technologies

Agilent Part Number: E8362-90002

Printed in USA June 2002

© Copyright 2002 Agilent Technologies, Inc. All rights reserved.



E8362-90002

Notice

THE MATERIAL CONTAINED IN THIS DOCUMENT IS PROVIDED “AS IS,” AND IS SUBJECT TO BEING CHANGED, WITHOUT NOTICE, IN FUTURE EDITIONS. FURTHER, TO THE MAXIMUM EXTENT PERMITTED BY APPLICABLE LAW, AGILENT DISCLAIMS ALL WARRANTIES, EITHER EXPRESS OR IMPLIED WITH REGARD TO THIS MANUAL AND ANY INFORMATION CONTAINED HEREIN, INCLUDING BUT NOT LIMITED TO THE IMPLIED WARRANTIES OF MERCHANTABILITY AND FITNESS FOR A PARTICULAR PURPOSE. AGILENT SHALL NOT BE LIABLE FOR ERRORS OR FOR INCIDENTAL OR CONSEQUENTIAL DAMAGES IN CONNECTION WITH THE FURNISHING, USE, OR PERFORMANCE OF THIS DOCUMENT OR ANY INFORMATION CONTAINED HEREIN. SHOULD AGILENT AND THE USER HAVE A SEPARATE WRITTEN AGREEMENT WITH WARRANTY TERMS COVERING THE MATERIAL IN THIS DOCUMENT THAT CONFLICT WITH THESE TERMS, THE WARRANTY TERMS IN THE SEPARATE AGREEMENT WILL CONTROL.

Getting Assistance from Agilent

By internet, phone, or fax, get assistance with all your test and measurement needs.

Online assistance: www.agilent.com/find/assist		
United States <i>(tel)</i> 1 800 452 4844	Latin America <i>(tel)</i> (305) 269 7500 <i>(fax)</i> (305) 269 7599	Canada <i>(tel)</i> 1 877 894 4414 <i>(fax)</i> (905) 282-6495
Europe <i>(tel)</i> (+31) 20 547 2323 <i>(fax)</i> (+31) 20 547 2390	Australia <i>(tel)</i> 1 800 629 485 <i>(fax)</i> (+61) 3 9210 5947	New Zealand <i>(tel)</i> 0 800 738 378 <i>(fax)</i> (+64) 4 495 8950
Japan <i>(tel)</i> (+81) 426 56 7832 <i>(fax)</i> (+81) 426 56 7840	Singapore <i>(tel)</i> 1 800 375 8100 <i>(fax)</i> (65) 836 0252	Malaysia <i>(tel)</i> 1 800 828 848 <i>(fax)</i> 1 800 801 664
India <i>(tel)</i> 1 600 11 2929 <i>(fax)</i> 000 800 650 1101	Hong Kong <i>(tel)</i> 800 930 871 <i>(fax)</i> (852) 2506 9233	Taiwan <i>(tel)</i> 0800 047 866 <i>(fax)</i> (886) 2 25456723
Philippines <i>(tel)</i> (632) 8426802 <i>(tel)</i> (PLDT subscriber only) 1 800 16510170 <i>(fax)</i> (632) 8426809 <i>(fax)</i> (PLDT subscriber only) 1 800 16510288	Thailand <i>(tel)</i> (outside Bangkok) (088) 226 008 <i>(tel)</i> (within Bangkok) (662) 661 3999 <i>(fax)</i> (66) 1 661 3714	People’s Republic of China <i>(tel)</i> (preferred) 800 810 0189 <i>(tel)</i> (alternate) 10800 650 0021 <i>(fax)</i> 10800 650 0121

About Installing the Upgrade Kit

Products affected.	E8362A; all options
Installation to be performed by	Agilent service center or personnel qualified by Agilent
Estimated installation time	1 hour
Estimated verification time	5 minutes

Description of Option UNL

This option adds a 60-dB step attenuator and a bias tee between the switch splitter and each of the front panel test ports.

The step attenuators are used to adjust the power level to the device under test (DUT) without changing the power in the reference path.

The bias tees provide a means of biasing active devices under test. DC bias for the bias tees is provided through two rear-panel BNC connectors. These inputs are fused for protection.

Items Included in the Upgrade Kit

Table 1 lists the parts included in this upgrade kit, Agilent part number E8362-60103. Check the contents of your kit against this list. If any item is missing or damaged, contact Agilent Technologies. Refer to [“Getting Assistance from Agilent” on page 2](#).

Table 1 Contents of Option UNL Upgrade Kit (E8362-60103)

Ref. Desig.	Description	Qty	Part Number
The following parts are required for all analyzers			
	Installation note (this document)	1	E8362-90002
	Machine screw, M3.0 x 8 CWPNTX (for attaching attenuators)	4	0515-0372
	Machine screw, M2.5 x 14 CWPNTX (for attaching bias tees)	4	0515-2141
	Cable clamp	1	1400-1439
A36, A37	60-dB step attenuator	2	33325-60004
A38, A39	Bias tee (cable included)	2	5087-7239
	Ribbon cable (for A36 step attenuator)	1	8121-0819
	Ribbon cable (for A37 step attenuator)	1	8121-0119
W51	RF cable, A22 switch splitter to A36 step attenuator	1	E8364-20055
W52	RF cable, A22 switch splitter to A37 step attenuator	1	E8364-20056
W55	RF cable, A38 bias tee to A25 test port 1 coupler	1	E8364-20051
W56	RF cable, A39 bias tee to A26 test port 2 coupler	1	E8364-20052
The following parts are required only for analyzers without Option 014 installed			
W7	RF cable, channel R1 attenuator to A28 channel R1 mixer	1	E8362-20027
W8	RF cable, channel R2 attenuator to A29 channel R2 mixer	1	E8362-20028
W53	RF cable, A36 step attenuator to A38 bias tee	2	E8364-20077
W54	RF cable A37 step attenuator to A39 bias tee		
The following parts are required only for analyzers with Option 014 installed			
	Lower front panel overlay (Option UNL/014)	1	E8364-80011
W70	RF cable, RCVR R1 IN to A28 channel R1 mixer	1	E8362-20014
W71	RF cable, RCVR R2 IN to A29 channel R2 mixer	1	E8362-20015
W81	RF cable, A36 step attenuator to Port 1 SOURCE OUT	1	E8362-20024
W82	RF cable, A37 step attenuator to Port 2 SOURCE OUT	1	E8362-20025
W83	RF cable, PORT 1 CPLR THRU to A38 bias tee	1	E8362-20012
W84	RF cable, PORT 2 CPLR THRU to A39 bias tee	1	E8362-20013

Installation Procedure for the Upgrade Kit

The network analyzer must be in proper working condition prior to installing this option. Any necessary repairs must be made before proceeding with this installation.

WARNING **This installation requires the removal of the analyzer's protective outer covers. The analyzer must be powered down and disconnected from the mains supply before performing this procedure.**

Electrostatic Discharge Protection

Protection against electrostatic discharge (ESD) is essential while removing or connecting cables or assemblies within the network analyzer.

Static electricity can build up on your body and can easily damage sensitive internal circuit elements when discharged. Static discharges too small to be felt can cause permanent damage. To prevent damage to the instrument:

- *always* wear a grounded wrist strap having a 1 M Ω resistor in series with it when handling components and assemblies.
- *always* use a grounded, conductive table mat while working on the instrument.
- *always* wear a heel strap when working in an area with a conductive floor. If you are uncertain about the conductivity of your floor, wear a heel strap.

Figure 1 shows a typical ESD protection setup using a grounded mat and wrist strap. Refer to “Tools and Equipment Required for the Installation” on page 6 for part numbers.

Figure 1 **ESD Protection Setup**

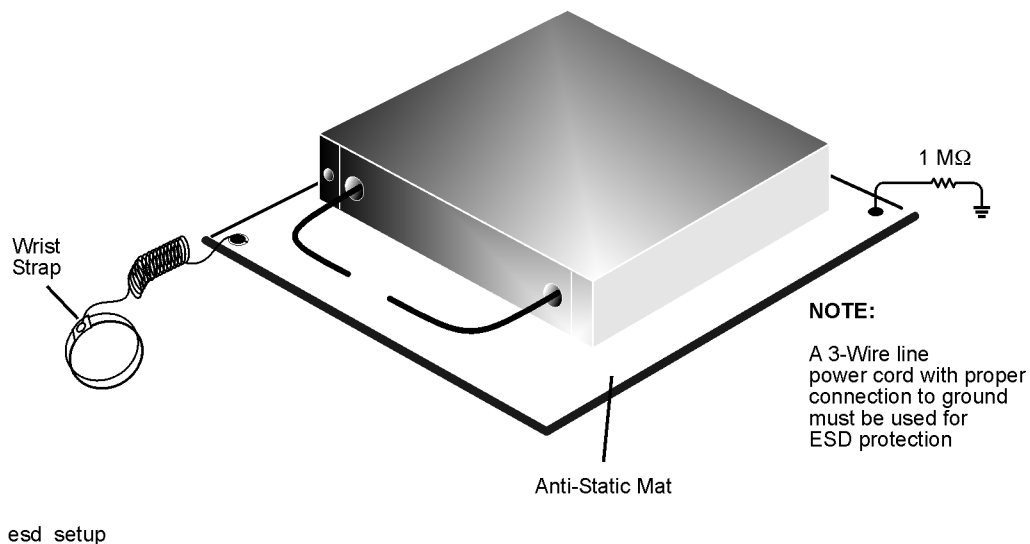

Overview of the Installation Procedure

The following steps comprise the installation of the Option UNL upgrade kit.

1. Remove the outer cover.
2. Remove the front panel assembly (Option 014 only).
3. Raise the receiver deck.
4. Remove the existing cables.
5. Install the attenuators and bias tees.
6. Install the Option UNL cables.
7. Lower and fasten the receiver deck and connect the bias tee control cables.
8. Replace the lower front panel overlay (Option 014 only).
9. Reinstall the front panel assembly and front panel jumpers (Option 014 only).
10. Reinstall the outer cover.
11. Enable Option UNL.
12. Verify that Option UNL is enabled.

Tools and Equipment Required for the Installation

Description	Qty	Part Number
T-10 TORX driver (set to 9 in-lbs)	1	N/A
T-20 TORX driver (set to 21 in-lbs)	1	N/A
5/16 in torque wrench (set to 10 in-lbs)	1	N/A
5/16 in torque wrench (set to 21 in-lbs) (Option 014 only)	1	N/A
ESD grounding wrist strap	1	9300-1367
5 ft grounding cord for wrist strap	1	9300-0980
2 x 4 ft conductive table mat and 15 ft grounding wire	1	9300-0797
ESD heel strap (for use with conductive floors)	1	9300-1308

CAUTION Use a 5/16-in torque wrench set to 10 in-lbs on all cable connections except the front-panel connectors to which the front-panel jumpers attach (Option 014). Use a 5/16-in torque wrench set to 21 in-lbs for these connections.

Step 1. Remove the Outer Cover

CAUTION This procedure is best performed with the analyzer resting on its front handles in the vertical position. *Do not place the analyzer on its front panel without the handles.* This will damage the front panel assemblies.

Refer to [Figure 2](#) for this procedure.

1. Disconnect the power cord (if it has not already been disconnected).
2. With a T-20 TORX driver, remove the strap handles (item ①) by loosening the screws (item ②) on both ends until the handle is free of the analyzer.
3. With a T-20 TORX driver, remove the four rear panel feet (item ③) by removing the center screws (item ④).
4. Slide the four bottom feet (item ⑤) off the cover.
5. Slide the cover off of the frame.

Figure 2 Outer Cover Removal

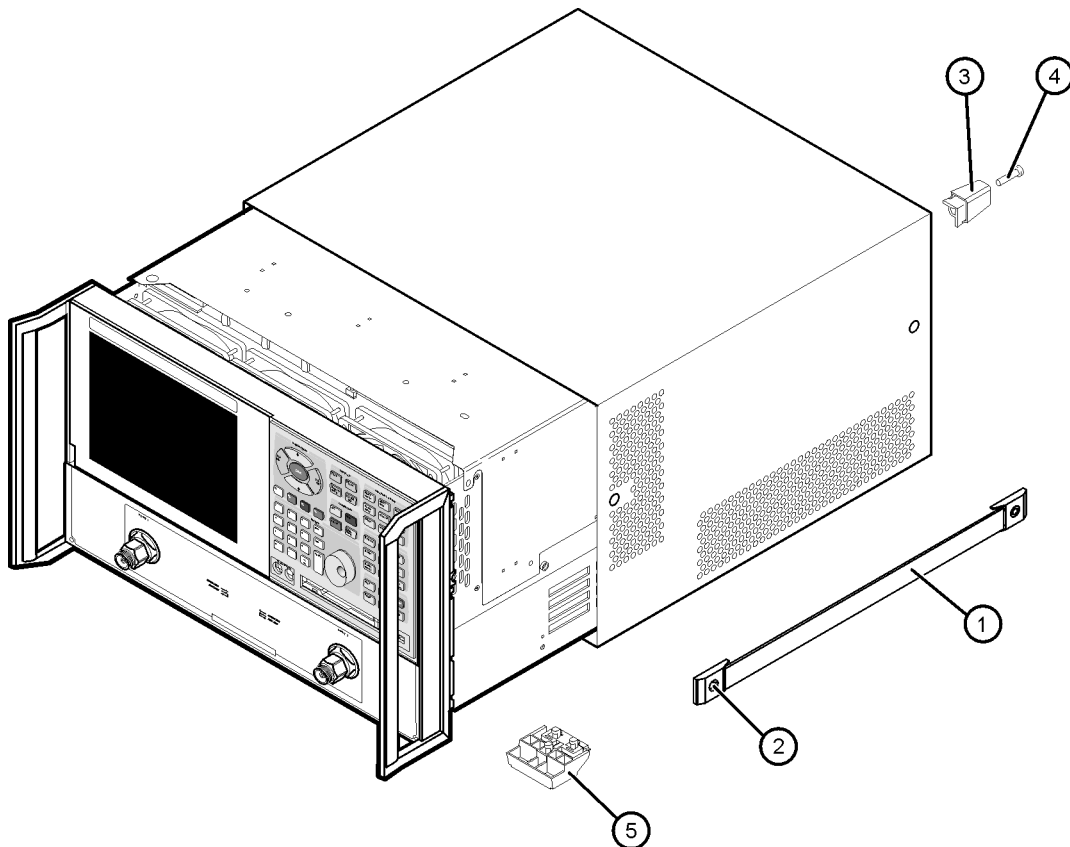

dt501a

Step 2. Remove the Front Panel Assembly (Option 014 Only)

Refer to [Figure 3](#) for this procedure.

1. With a 5/16-inch wrench, remove the six front panel semirigid jumper cables (item ①).
2. With a T-10 TORX driver, remove the eight screws (item ②) from the sides of the frame.

CAUTION Before removing the front panel from the analyzer, lift and support the front of the analyzer chassis.

3. Slide the front panel over the test port connectors.
4. Disconnect the front panel interface ribbon cable (item ③) from the A3 front panel interface board. The front panel is now free from the analyzer.

Figure 3 Front Panel Assembly Removal

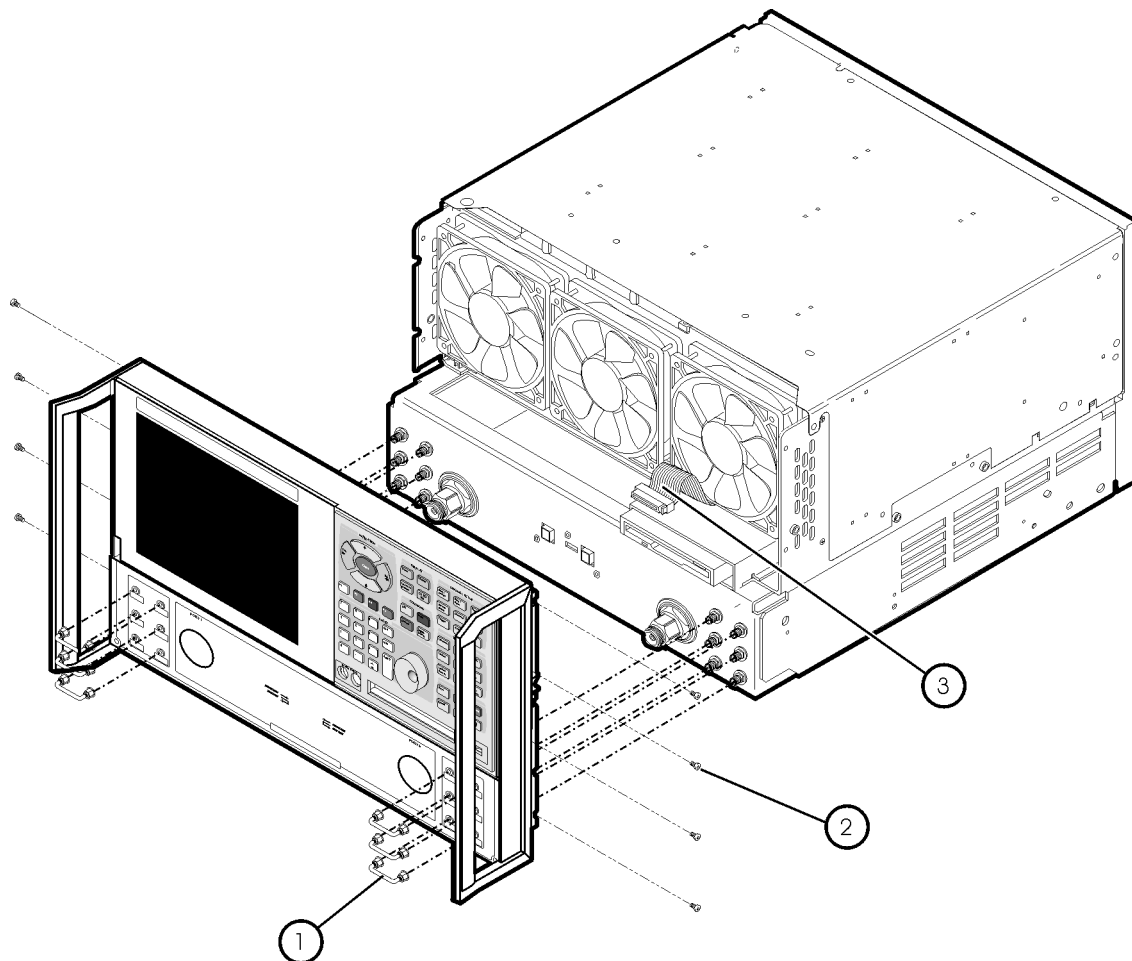

st536a

Step 3. Raise the Receiver Deck

Refer to [Figure 4](#) for this procedure.

1. Place the analyzer bottom-side up on a flat surface.
2. With a T-10 TORX driver, remove the four screws, (item ①), that secure the receiver deck.
3. Pull the latch pin (item ②) towards the center of the analyzer to release the receiver deck.
4. Lift the receiver deck to partially raise it, then release the latch pin (item ②). Lift the receiver deck to its fully raised position and ensure that the latch pin latches in the raised position.

Figure 4 Receiver Deck, Raising

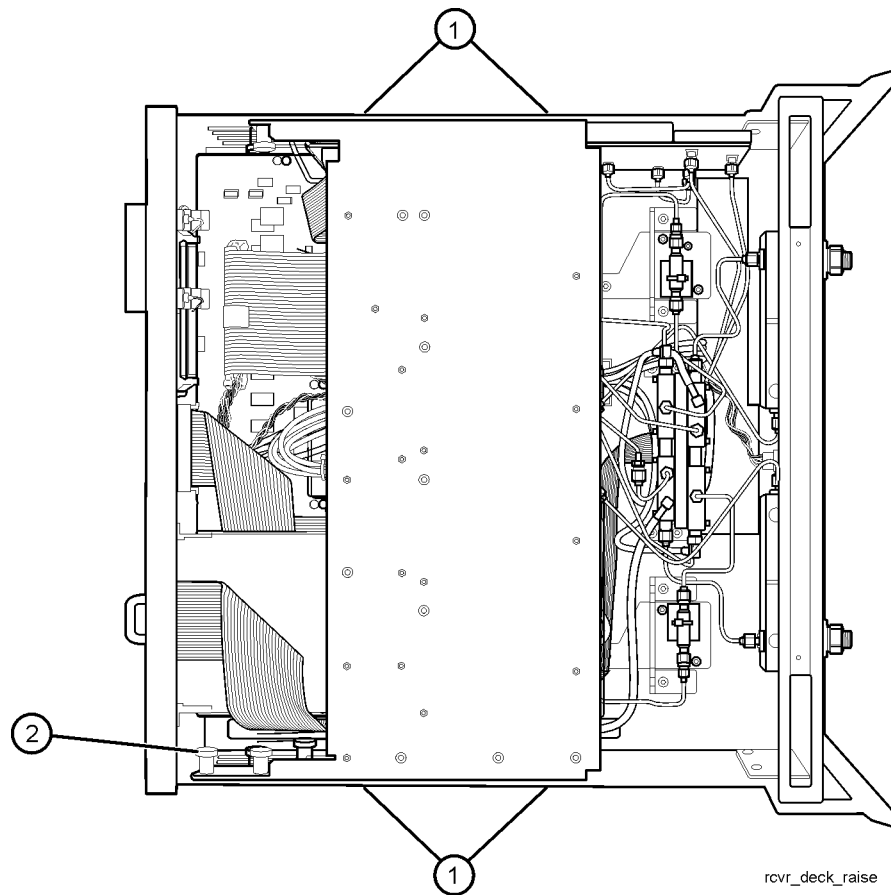

Step 4. Remove the Existing Cables

Analyzers without Option 014 Installed

Refer to [Figure 5](#) for the following procedure.

If you are installing Option UNL on an analyzer that does not have Option 014 installed, remove the following cables:

- W7 E8362-20005 Channel R1 fixed attenuator to A28 channel R1 mixer
- W8 E8362-20006 Channel R2 fixed attenuator to A29 channel R2 mixer
- W5 E8364-20021 A22 switch splitter to A25 test port 1 coupler
- W6 E8364-20022 A22 switch splitter to A26 test port 2 coupler

Figure 5 Cable Removal, Analyzers without Option 014

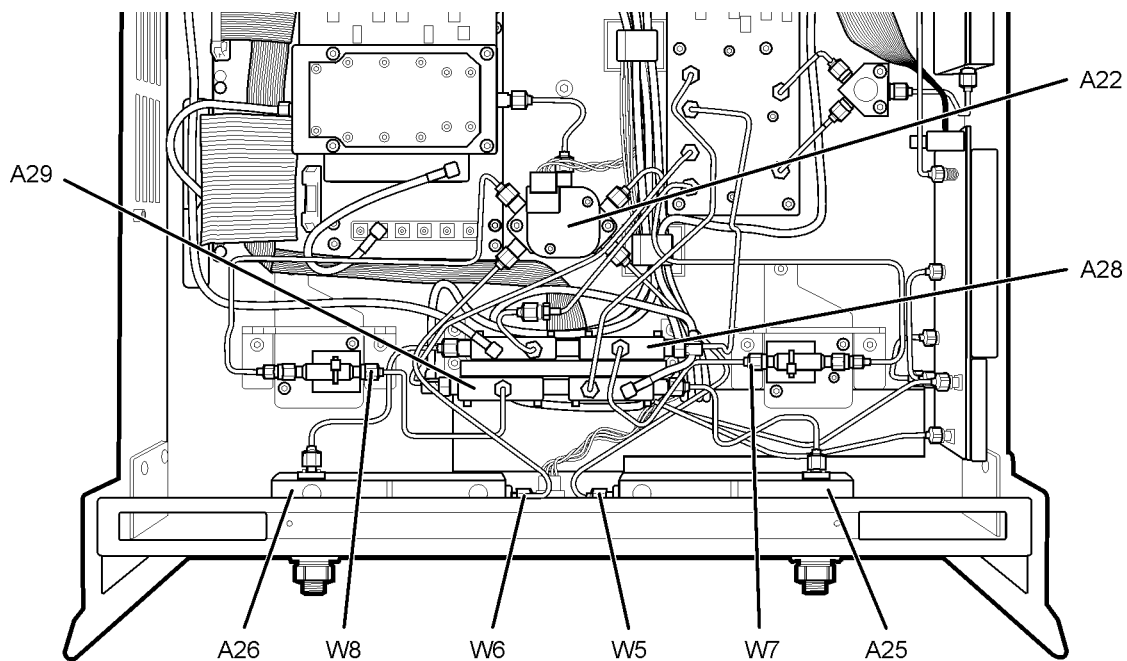

cbl_rmrv_std

Analyzers with Option 014 Installed

Refer to [Figure 6](#) for the following procedure.

If you are installing Option UNL on an analyzer that has Option 014 installed, remove the following cables:

- W63 E8362-20018 PORT 1 CPLR THRU to A25 test port 1 coupler
- W61 E8362-20016 A22 switch splitter to PORT 1 SOURCE OUT
- W64 E8362-20019 PORT 2 CPLR THRU to A26 test port 1 coupler
- W62 E8362-20017 A22 switch splitter to PORT 2 SOURCE OUT
- W71 E8362-20030 R2 IN to A29 channel R2 mixer
- W70 E8362-20029 R1 IN to A28 channel R1 mixer

Figure 6 Cable Removal, Analyzers with Option 014

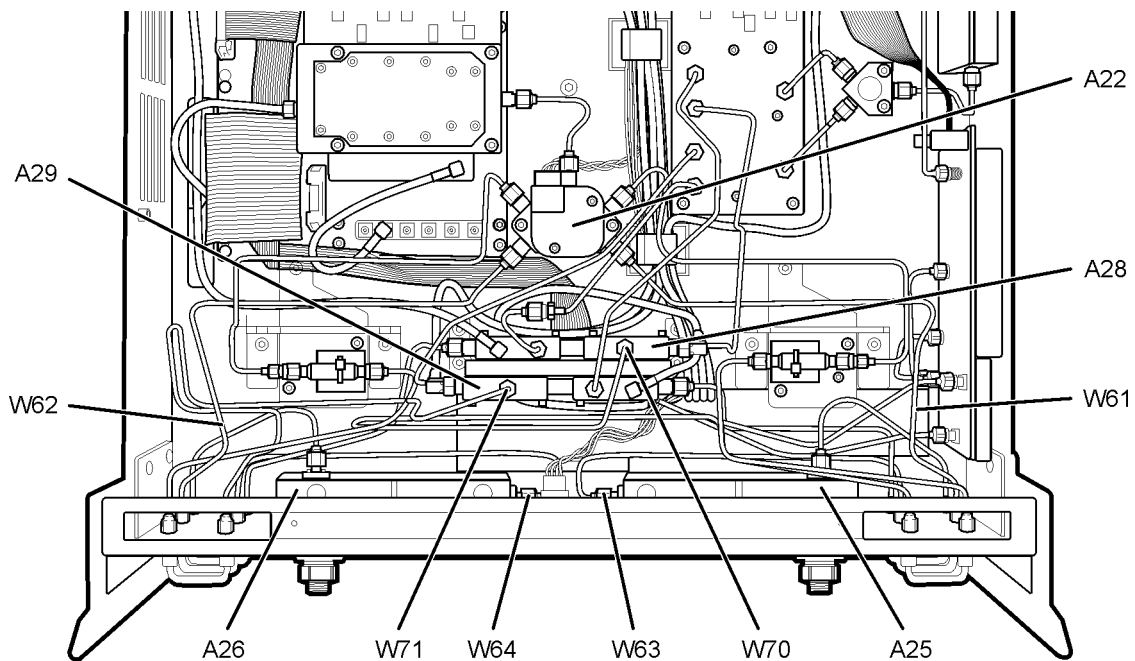

cbl_rmv_014

Step 5. Install the Attenuators and Bias Tees

Refer to [Figure 7](#) for this portion of the procedure.

To install the attenuators and bias tees, the brackets holding the fixed attenuators must be removed.

1. With a 5/16-inch torque wrench, disconnect, remove, and keep for reinstallation later, the two semirigid cables (item ①) from the fixed attenuators.
2. With a T-10 TORX driver, remove the three mounting screws (item ②) from each bracket holding the fixed attenuator.
3. Remove the brackets from the analyzer with the fixed attenuators attached.

Figure 7 Attenuator and Bias Tee Installation, Bracket Removal

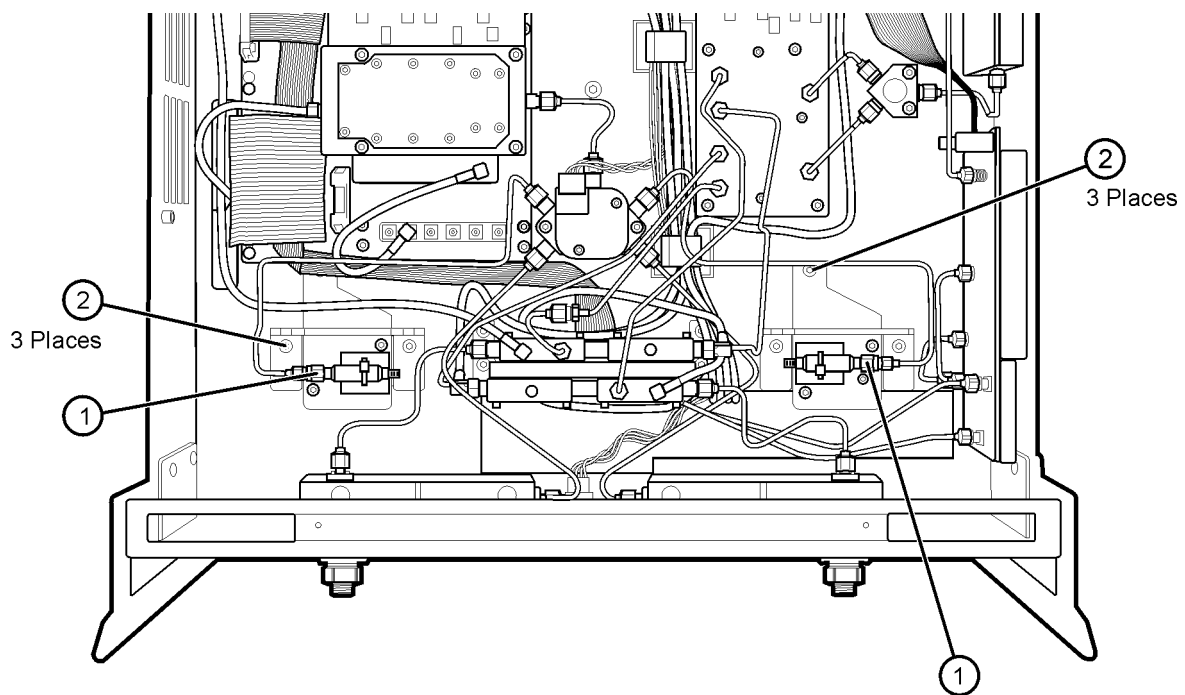

bkt_rmv

Refer to [Figure 8](#) for this portion of the procedure.

4. Attach one step attenuator to each bracket using two M3.0 x 8 screws (provided) for each.

Be careful to position the step attenuators so that the necessary cables can be attached. The end of the step attenuator with the ribbon cable connector must face toward the inside of the analyzer. Review the cable connections in [Figure 8](#) if necessary.

5. Attach one bias tee to each bracket using two M2.5 x 14 screws (provided) for each.

The bias tees mount beneath the fixed attenuators. Be careful to position the bias tees so that the necessary cables can be attached. The end of the bias tee with the wires attached must face toward the inside of the analyzer. Review the cable connections in [Figure 8](#) if necessary.

6. Reinstall the brackets in the analyzer with the step attenuators, bias tees, and fixed attenuators attached.

Figure 8 Attenuator and Bias Tee Installation, Bracket Installation

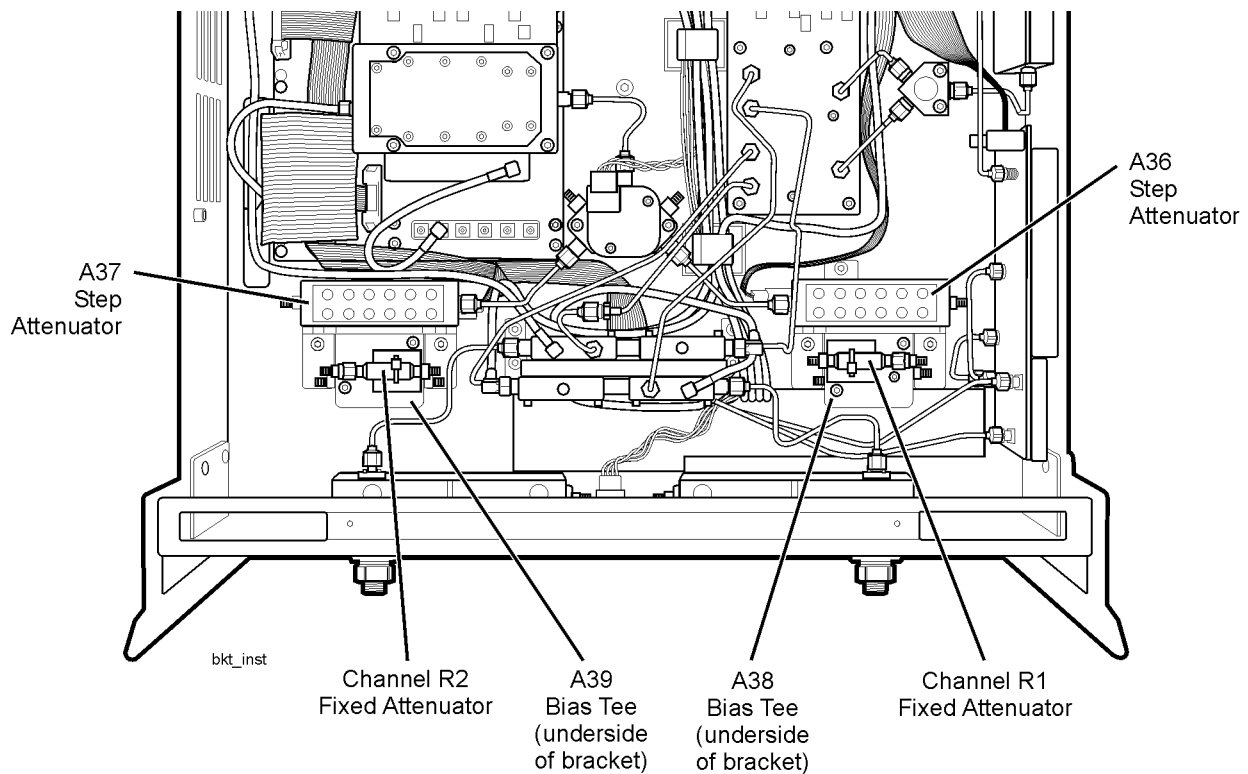

Step 6. Install the Option UNL Cables

Analyzers without Option 014 Installed

Refer to [Figure 9](#) for the following procedure. The new parts referenced in this procedure are listed in [Table 1 on page 4](#).

1. If you are installing Option UNL on an analyzer that does not have Option 014 installed, install the following cables in the order listed:
 - Ribbon cable ① 8121-0819 A36 step attenuator to A16 motherboard (P1 SRC ATT)
 - Ribbon cable ② 8121-0119 A37 step attenuator to A16 motherboard (P2 SRC ATT)
 - W52 E8364-20056 A22 switch splitter to A37 step attenuator
 - W51 E8364-20055 A22 switch splitter to A36 step attenuator
 - W8 E8362-20028 Channel R2 fixed attenuator to A29 channel R2 mixer
 - W7 E8362-20027 Channel R1 fixed attenuator to A28 channel R1 mixer
 - W56 E8364-20052 A39 bias tee to A26 test port 2 coupler
 - W55 E8364-20051 A38 bias tee to A25 test port 1 coupler
 - W54 E8364-20077 A37 step attenuator to A39 bias tee
 - W53 E8364-20077 A36 step attenuator to A38 bias tee
2. Route the bias tee control cables through the cable clamps, (item ③), to the rear of the analyzer for connection to the A16 motherboard later.
3. Reinstall the semirigid cables, (item ④), to the fixed attenuators.

Figure 9 Option UNL Cable Installation, Analyzers without Option 014

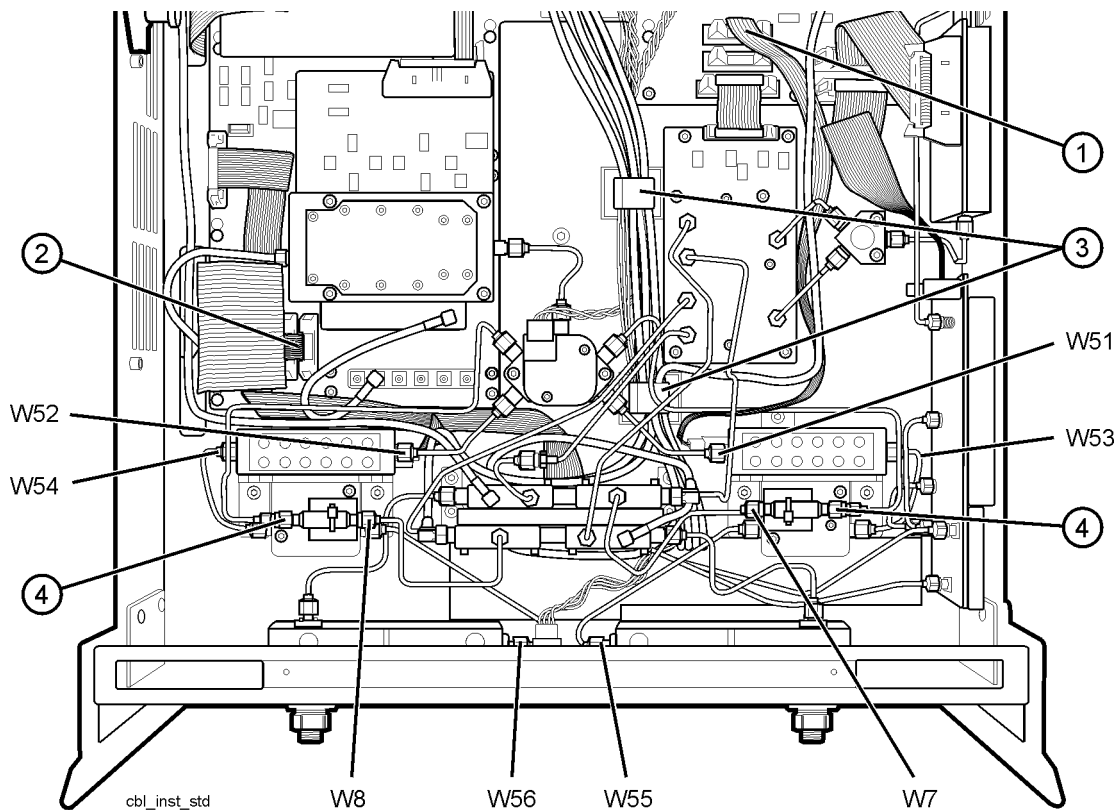

Analyzers with Option 014 Installed

Refer to [Figure 10](#) for the following procedure. The new parts referenced in this procedure are listed in [Table 1 on page 4](#).

1. If you are installing Option UNL on an analyzer that has Option 014 installed, install the following cables in the order listed:
 - Ribbon cable ① 8121-0819 A36 step attenuator to A16 motherboard (P1 SRC ATT)
 - Ribbon cable ② 8121-0119 A37 step attenuator to A16 motherboard (P2 SRC ATT)
 - W52 E8364-20056 A22 switch splitter to A37 step attenuator
 - W51 E8364-20055 A22 switch splitter to A36 step attenuator
 - W71 E8362-20015 R2 IN to A29 channel R2 mixer
 - W70 E8362-20014 R1 IN to A28 channel R1 mixer
 - W56 E8364-20052 A39 bias tee to A26 test port 2 coupler
 - W55 E8364-20051 A38 bias tee to A25 test port 1 coupler
 - W82 E8362-20025 A37 step attenuator to PORT 2 SOURCE OUT
 - W84 E8362-20013 PORT 2 CPLR THRU to A39 bias tee
 - W81 E8362-20024 A36 step attenuator to PORT 1 SOURCE OUT
 - W83 E8362-20012 PORT 1 CPLR THRU to A38 bias tee
2. Route the bias tee control cables through the cable clamps, (item ③), to the rear of the analyzer for connection to the A16 motherboard later.
3. Reinstall the semirigid cables, (item ④), to the fixed attenuators.

Figure 10 Option UNL Cable Installation, Analyzers with Option 014

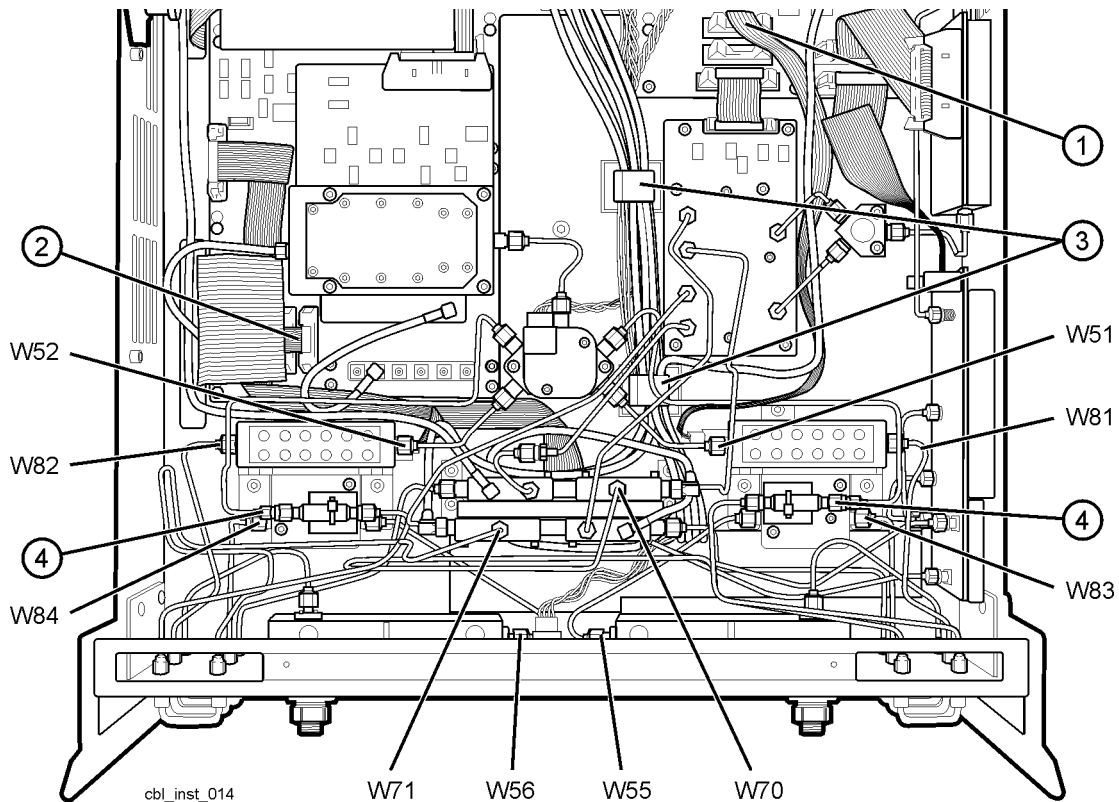

Step 7. Lower and Fasten the Receiver Deck and Connect the Bias Tee Control Cables

Refer to [Figure 11](#) for this procedure.

1. Pull the latch pin (item ②) toward the center of the analyzer to release the receiver deck.
2. Lift the receiver deck to partially lower it, then release the latch pin (item ②). Lower the receiver deck to its fully lowered position and ensure that the latch pin latches in the lowered position.
3. With a T-10 TORX driver, install the four screws (item ①) to secure the receiver deck.
4. Connect the bias tee cables to the A16 motherboard connectors as indicated.
5. The dc bias input connectors and fuse holders (fuses included) are already installed on the rear panel but covered. Using a T-10 TORX driver, remove the four screws from the cover and remove and discard the cover.

Figure 11 Receiver Deck, Lowering

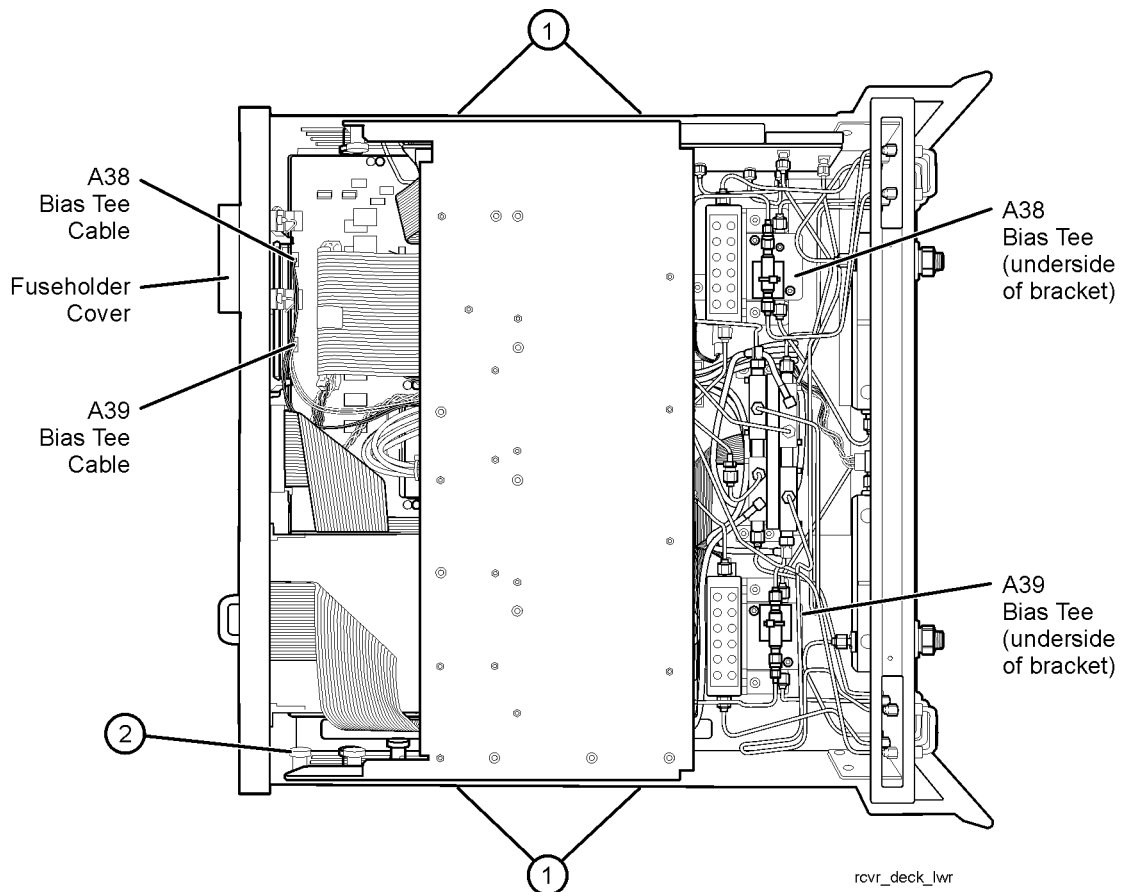

Step 8. Replace the Lower Front Panel Overlay (Option 014 Only)

NOTE The new parts referenced in this procedure are listed in [Table 1 on page 4](#).

Refer to [Figure 12](#) for this procedure.

1. From the back side of the front panel, use a blunt object in one of the cutouts in the frame to push the overlay (item ①) and separate it from the front panel.
2. From the front side of the front panel, pull the overlay completely off and discard it.
3. Remove any adhesive remaining on the front panel.
4. Remove the protective backing from the new Option 014 front panel overlay (item ①).
5. Starting from either the left or right side, *loosely* place the overlay in the recess on the lower front panel, ensuring that it fits tightly against the recess edges.
6. Once the overlay is in place, press it firmly onto the frame to secure it.

Figure 12 Lower Front Panel Overlay Replacement

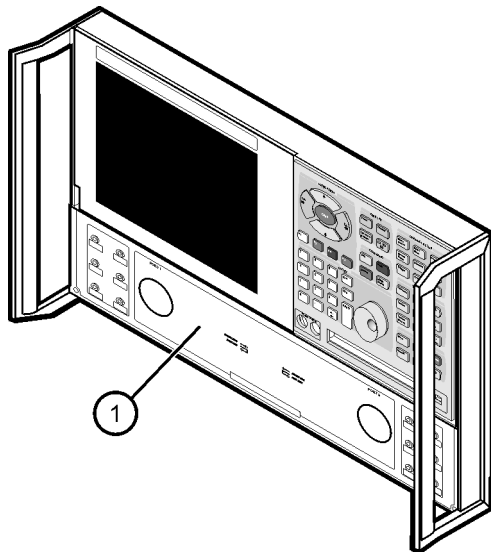

dt510a

Step 9. Reinstall the Front Panel Assembly and Front Panel Jumpers (Option 014 Only)

CAUTION Before installing the front panel assembly onto the analyzer, lift and support the front of the analyzer chassis.

Refer to [Figure 13](#) for this procedure.

1. Tighten all 12 of the front-panel feed-through connectors using a 5/16-in torque wrench set to 21-in lbs.
2. Reconnect the ribbon cable (item ①) to the A3 front panel interface board.
3. Slide the front panel over the test port connectors being careful to align the power switch and floppy disk drive to their corresponding front panel cutouts. Ensure that the ribbon cable ① is located below the fan to prevent it from being damaged by the fan blades.
4. With a T-10 TORX driver, install the eight screws (item ②) in the sides of the frame.
5. Install the six semirigid jumpers (item ③) on the front panel and tighten to 10-in lbs.

Figure 13 Front Panel Assembly Reinstallation

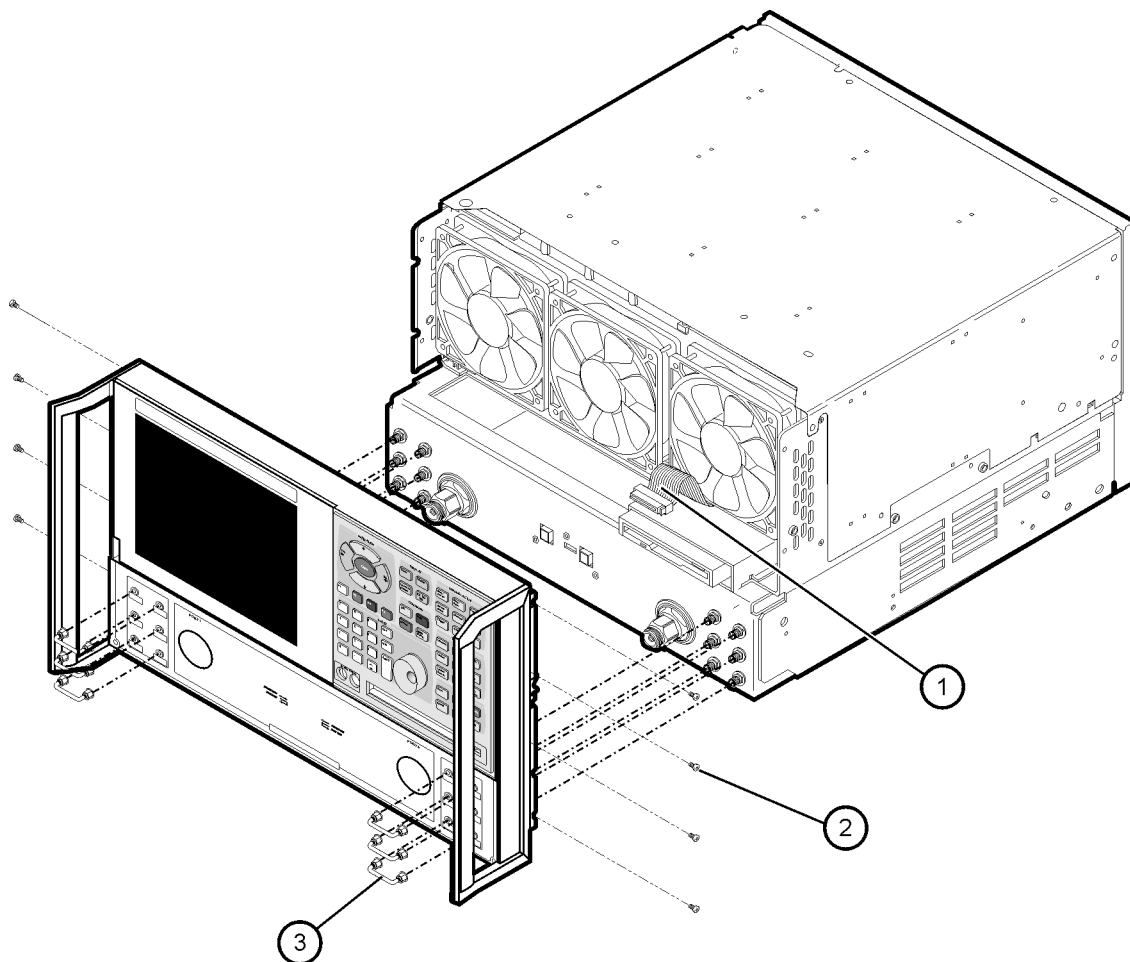

dt511a

Step 10. Reinstall the Outer Cover

CAUTION This procedure is best performed with the analyzer resting on its front handles in the vertical position. *Do not place the analyzer on its front panel without the handles.* This will damage the front panel assemblies.

Refer to [Figure 14](#) for this procedure.

1. Slide the cover over the analyzer frame.
2. With a T-20 TORX driver, install the four rear panel feet (item ①) by installing the center screws (item ②).
3. Slide the four bottom feet (item ③) into position on the cover.
4. With a T-20 TORX driver, install the strap handles (item ④) by installing the screws (item ⑤) on both ends of the handle.

Figure 14 Outer Cover Reinstallation

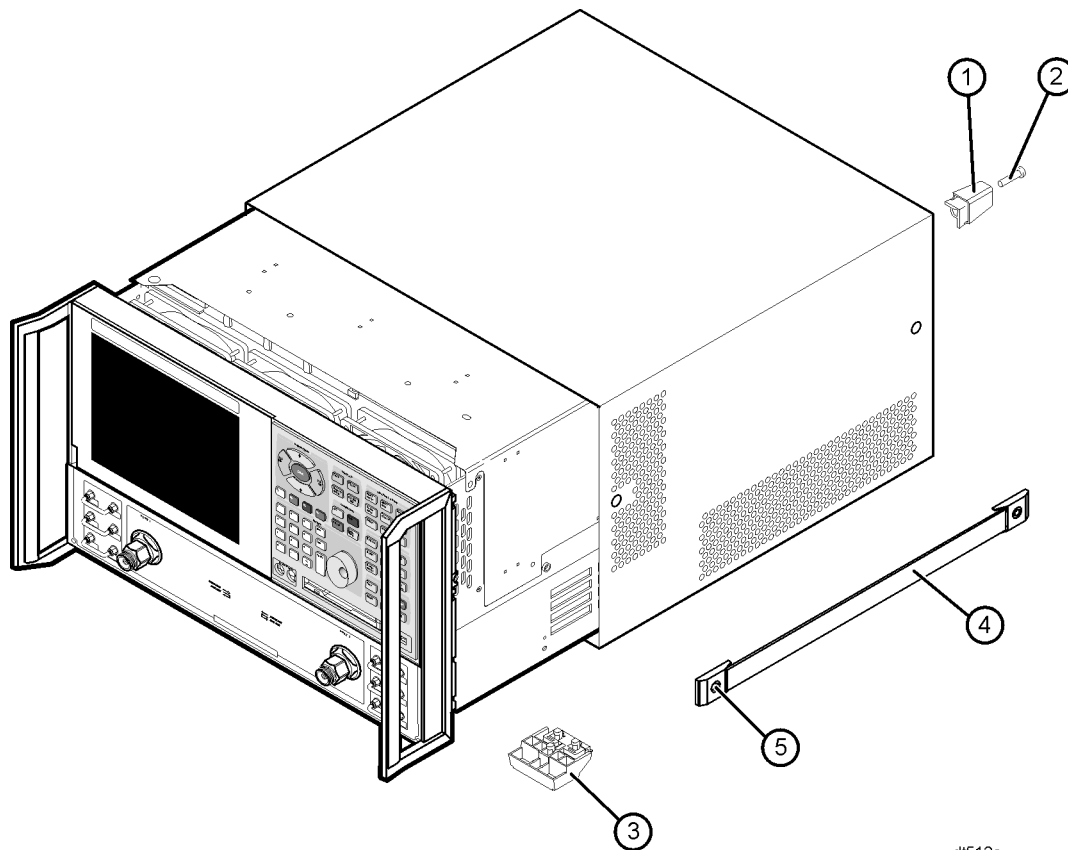

dt512a

Step 11. Enable Option UNL

Procedure Requirements

- The analyzer must be powered up and operating to perform this procedure.
- The Network Analyzer program must be running.
- A mouse is recommended for this procedure but is not required.

Mouse Procedure

1. On the analyzer's **System** menu, point to **Service**, and then click **Option Enable**.
2. In the **Select Desired Option** list, click **UNL - Bias Tees w/Atten**.
3. Click **Install**.
4. Click **Yes** in answer to the displayed question in the **Restart Analyzer?** box.
5. When the installation is complete, click **Exit**.

Front Panel Keys Procedure

1. In the **COMMAND** block, press **Menu/Dialog**.
2. In the **NAVIGATION** block, press the Right Tab and Arrows to move over to the **System** menu and down to the **Service** selection. Press the Right Tab to display the extended menu and the Arrows to select **Option Enable**. Press **Click**.
3. Tab to the **Select Desired Option** list, and press Arrows to select **UNL - Bias Tees w/Atten**.
4. Tab to **Install**, and then press **Click**.
5. Click **Yes** in answer to the displayed question in the **Restart Analyzer?** box.
6. When the installation is complete, in the **COMMAND** block, press **OK** (or tab to **OK**, and then press **Click**).

Step 12. Verify that Option UNL Is Enabled

Procedure Requirements

- The analyzer must be powered up and operating to perform this procedure.
- The Network Analyzer program must be running.
- A mouse is recommended for this procedure but is not required.

Mouse Procedure

1. On the analyzer's **Help** menu, click **About Network Analyzer**.
2. Verify that "UNL" is listed after "Options:" in the display. Click **OK**.

NOTE If Option UNL has not been enabled, perform step 11 again. If the option is still not enabled, contact Agilent Technologies. Refer to ["Getting Assistance from Agilent" on page 2](#).

Front Panel Keys Procedure

1. In the **COMMAND** block, press **Menu/Dialog**.
2. In the **NAVIGATION** block, press the Right Tab and Arrows to move over to the **Help** menu, and down to the **About Network Analyzer** selection. Press **Click**.
3. Verify that "UNL" is listed after "Options:" in the display. In the **COMMAND** block, press **OK** (or tab to **OK**, and then press **Click**).

NOTE If Option UNL has not been enabled, perform step 11 again. If the option is still not enabled, contact Agilent Technologies. Refer to ["Getting Assistance from Agilent" on page 2](#).
